

CAD FILE:

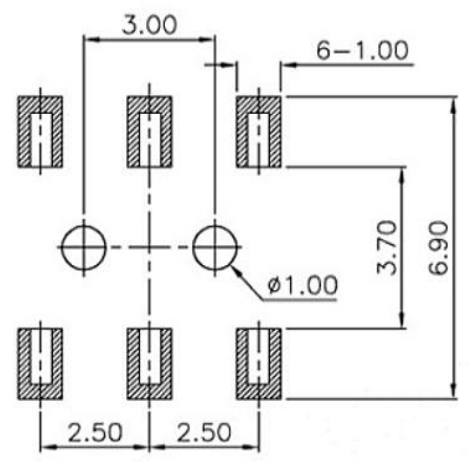

PCB Layout(Pattern side)

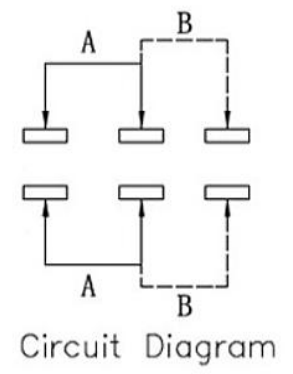
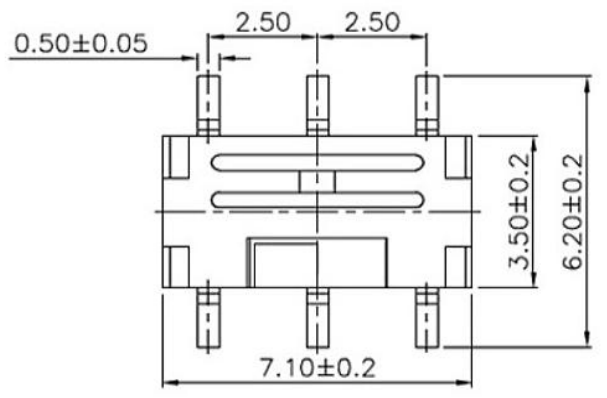
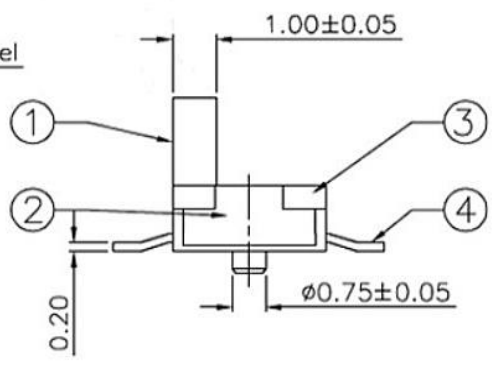
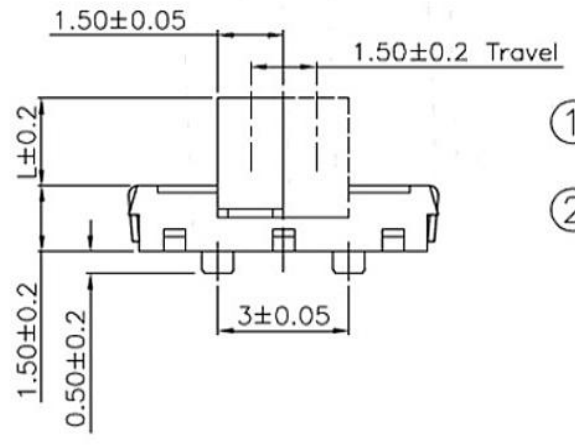

注: "*"表示关键尺寸(6个)

NO.	PARTS	MATERIALS	Q'TY	FINISH	TOLERANCE UNLESS SPECIFIED		DESCRIPTIONS OF REVISION		APPD.
8									
7	STEEL BALL	STEEL	1	NATURAL					
6	SPRING	STEEL WIRE	1	NATURAL					
5	CONTACT CLIP	PBS STRIP	2	Ag PLATED					
4	TERMINAL	BRASS STRIP	8	Ag PLATED					
3	BASE	PHENOLIC RESIN	1	NATURAL					
2	FRAME	STEEL STRIP	1	Ni PLATED					
1	KNOB	POM	1	BLACK					
					TITLE : SLIDE SWITCH		UNIT : mm	DRWG NO.:	
					MODEL:		SCALE: 3:1	DWN.	2012-10-26
					東莞市高迪電子有限公司 DONGGUAN GAODI ELECTRONICS CO., LTD.		ISSUE		2012-10-26
							DATE		2012-10-26
							APPD.		2012-10-26